

# GAMMA COLORI | COLOUR RANGE

## ESSENZE | WOODS cat. 1



rovere naturale  
natural oak



rovere visone  
oak visone

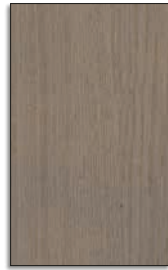

rovere cenere  
oak cenere

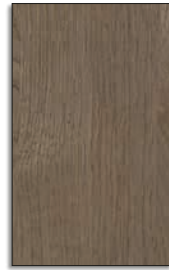

rovere castoro  
oak castoro



rovere carbone  
oak carbone

## ESSENZE | WOODS cat. 2

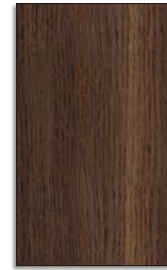

rovere termotrattato  
heat - treated oak



noce Canaletto  
Canaletto walnut

## CANNETÉ solo per anta Marlene, con decoro irregolare | only for Marlene door, with irregular decoration



rovere naturale  
natural oak



rovere visone  
oak visone

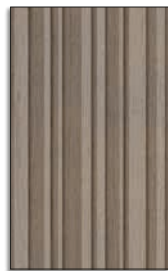

rovere cenere  
oak cenere



rovere castoro  
oak castoro



rovere carbone  
oak carbone



tinta rovere termotrattato  
heat - treated oak finish



tinta noce Canaletto  
Canaletto walnut finish

## MATERICI ESTERNI | EXTERNAL TEXTURED FINISHES

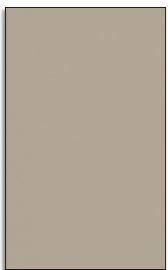

avana



rovere carbone  
oak carbone

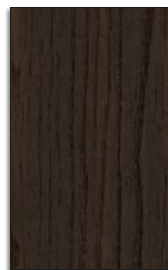

rovere termotrattato  
heat - treated oak



pietra piasentina

## MATERICO INTERNO abbinato nel lato esterno ad essenza o laccato INNER TEXTURED FINISH matching with wood or lacquer external finish

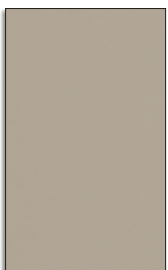

\*\* avana

\*\* L'interno di madie e contenitori è in materico avana, disponibile anche laccato opaco con maggiorazione del 20%. I mobili con esterno in materico avranno l'interno della stessa finitura materica.  
The inner finish of sideboards and storage units is textured avana, available in matt lacquer finish with a 20% surcharge. Furniture with textured external finish will be supplied with the same internal textured finish.

## LACCATI OPACI E LUCIDI - VETRI LACCATI | MATT AND GLOSSY LACQUERS - LACQUERED GLASSES



9003 bianco RAL 9003	9010 panna RAL 9010	1013 fior di loto RAL 1013	9001 crema RAL 9001	9002 ghiaccio RAL 9002	68 grigio perla NCS S 1502-Y	7044 grigio seta RAL 7044	100 sabbia NCS S 1500-N	71 light grey NCS S 2002-Y	101 giallo senape NCS S 4040-Y10R
----------------------------	---------------------------	----------------------------------	---------------------------	------------------------------	------------------------------------	---------------------------------	-------------------------------	----------------------------------	---



0173 bruciato NCS S 3050-Y50R	3003 rosso RAL 3003	3005 rosso bordeaux RAL 3005	102 rosa cipria NCS S 3030-Y80R	63 tortora	62 canapa	61 corda	72 dark grey	74 terracotta NCS S 5010-Y70R	73 moka
-------------------------------------	---------------------------	------------------------------------	---------------------------------------	---------------	--------------	-------------	-----------------	-------------------------------------	------------

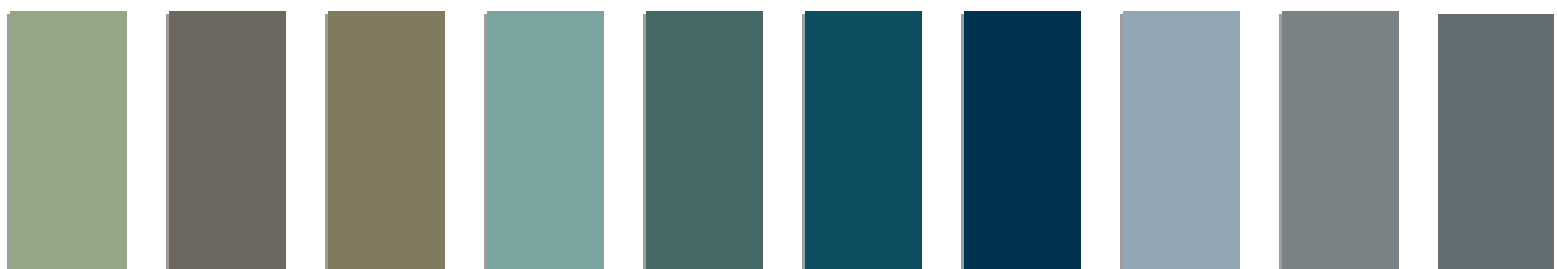

0190 verde pallido NCS S 3020-G30Y	7039 grigio aston RAL 7039	103 verde malva	0246 grigio Garda NCS S 3020-B60G	104 turchese NCS S 6020-B50G	105 oceano NCS S 6030-B10G	106 blu cobalto NCS S 7020-R90B	107 celeste NCS S 3020-B	76 carta da zucchero NCS S 5005-B20G	7031 grigio blu RAL 7031
--	----------------------------------	--------------------	---	------------------------------------	----------------------------------	---------------------------------------	--------------------------------	--	--------------------------------

### LACCATI OPACI MICALIZZATI METALLIC MATT LACQUERS

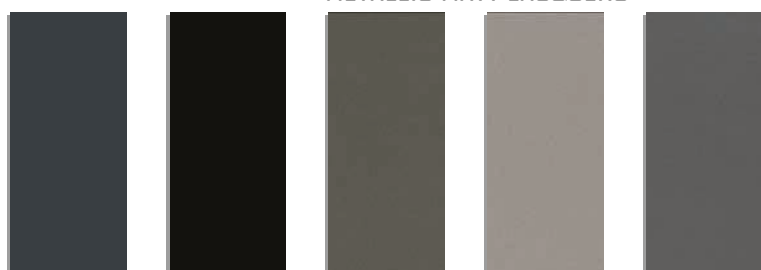

7016 grigio antracite RAL 7016	9017 nero RAL 9017	titanio	nichel	piombo
--------------------------------------	--------------------------	---------	--------	--------

#### LACCATO A CAMPIONE / RAL

Scala ral completa o tinta a campione con maggiorazione del 20%

#### CUSTOM COLOUR / RAL

Full ral scale or custom colour with a 20% surcharge

### VETRI TRASPARENTI TRANSPARENT GLASSES

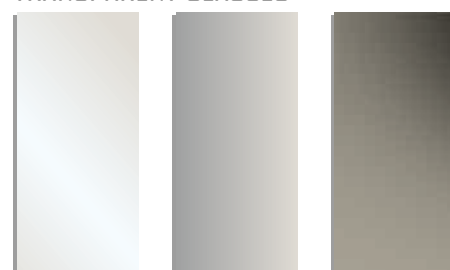

trasparente transparent	trasparente grigio grey transparent	trasparente bronzo bronze transparent
----------------------------	--	--

N.B.: La riproduzione dei colori su carta può risultare alterata rispetto agli originali, pertanto queste tinte sono da considerarsi indicativi. Anche i riferimenti di colore ncs sono puramente orientativi. Le vernici all'acqua utilizzate permettono di ridurre le emissioni di solventi in atmosfera, sono contraddistinte dall'assenza di odori e tutelano la salute dell'operatore e dell'utilizzatore finale.  
N.B.: The reproduction of the colours on paper may be different compared to the original ones, therefore these shades should be considered representative only. Ncs colour references are purely illustrative. Water-based varnishes reduce the impact of the atmospheric emission of solvents and are characterized by the lack of scent, safeguarding the operator's and end consumer's health.

## SUPERFICI UP | UP SURFACE

### Laccati effetto cemento | Concrete lacquered effects



perla



argilla



grafite



lava

### Laccati metallici | Metal effect lacquers



titanio



nichel



piombo

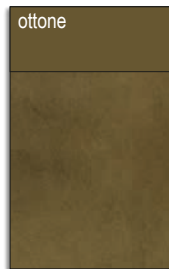

ottone

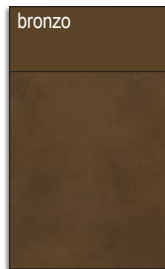

bronzio

laccati opachi per interni abbinati agli ossidi  
matt lacquers for interiors matching with ossido finishes

### GRES finitura opaca effetto pietra | stone effect gres with matt finish



azalai nero



jasper moka



storm grigio

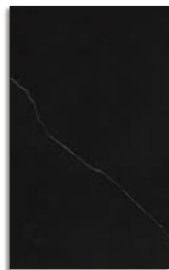

storm nero

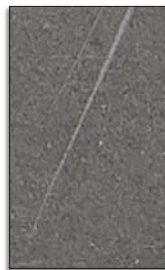

senda grigio



pacifico bianco

Lastra intera dimensione massima 3200 x 1500  
disponibile nello spessore 6 e 4 mm  
1-piece sheet, maximum dim. 3200 x 1500,  
available with 6 and 4 mm thickness

### GRES finitura lucida | glossy finish

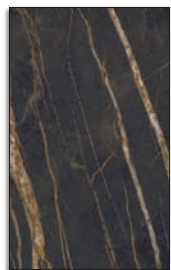

noir desir



calacatta oro

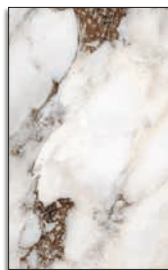

breche capraia

Lastra intera dimensione massima 3200 x 1500  
disponibile nello spessore 6 mm  
1-piece sheet, maximum dim. 3200 x 1500,  
available with 6 mm thickness

N.B.: Le finiture dei gres, dei metalli, ed in particolare della finitura artigianale ottone anticato, possono essere soggette a variazioni cromatiche poichè i nostri prodotti sono costituiti da materie prime naturali, per le quali è normale una variazione di tonalità; eventuali differenze di colore non sono da considerarsi difetti bensì peculiarità dei prodotti stessi.

N.B.: Finishes of gres, metals and particularly of handmade antiqued brass, may be exposed to colour variations because our products are made of raw materials which are naturally subject to tonality change. Any possible difference should be considered as a specific feature of the same product, rather than a flaw.

GLASS UP ante vetro | glass doors

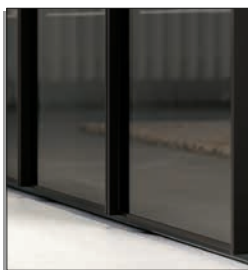

telaio finitura brown e nero  
frame in brown and black finish

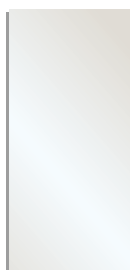

trasparente  
transparent



trasparente grigio  
grey transparent



trasparente bronzo  
bronze transparent

SLIM ante telaio | frame doors

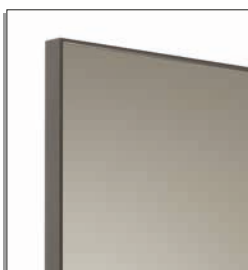

telaio finitura brown, nero, titanio e ottone anticato  
frame in brown, titanium, black and antiqued brass finish



Ante telaio abbinabili a tutta la gamma colori dei vetri, al pannello dell'anta Marlene oppure al Gres solo in finitura opaca. Il Gres in finitura opaca sp. 4 mm, presenta nel lato interno una rete trattata come nella foto.

Frame doors matching with the whole colour range of glasses, Marlene door or Gres only in matt finish. Gres in matt finish th. 4 mm features, on the inner side, a net treated as per the picture.

METALLI | METALS cat. 1

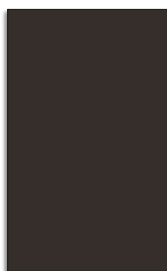

finitura brown  
brown finish



finitura titanio  
titanium finish

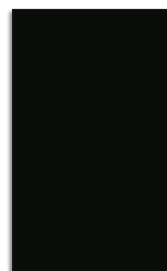

finitura nero  
black finish

METALLO | METAL cat. 2



finitura ottone anticato  
antiqued brass finish

VERO CUOIO | HARD LEATHER

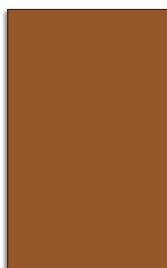

naturale



beige



corda



grigio

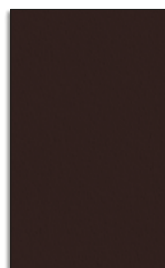

testa di moro



nero

ATTENZIONE: i vetri trasparenti lasciano intravedere il telaio sottostante dell'anta vetro Slim.  
ATTENTION: the transparent glasses allow a glimpse of the underlying frame of Slim glass door.

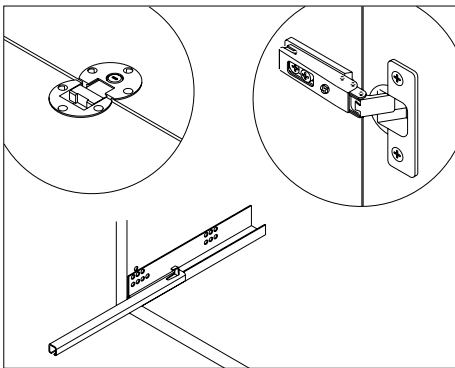

## SISTEMI DI APERTURA-CHIUSURA | OPENING AND CLOSING SYSTEMS

Sono previste 3 tipologie di apertura in base al modello: Anta battente - Ribalta - Cassetti/Cestoni.

Le ante sono previste con apertura push (con cricchetto a spinta). Le ante con maniglia o con presa diretta sono dotate di cerniere con sistema di chiusura ammortizzato (soft).

Le ribalte con apertura verso il basso hanno cerniere piatte con apertura push.

I cassetti/cestoni in battuta di serie sono dotati di guide con apertura push e sincronizzatore che ne facilita l'apertura.

Three opening systems are provided according to the model: Hinged door - Flap door - Drawers/ Deep drawers.

The doors are provided with a push opening (push to open magnet). The doors with handle or direct grip are equipped with dampened hinges (soft closing system). The flap-doors with downward opening have flat hinges with push opening.

Standard jutting drawers are equipped with a push-pull runner system and a synchronizer which simplifies their opening.

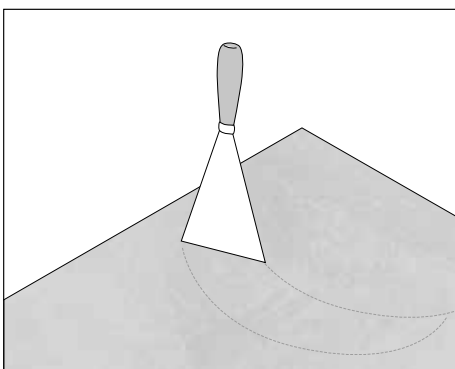

## SUPERFICI UP | UP SURFACE

Le finiture laccato effetto cemento e laccato metallico sono realizzate con vernici a basso residuo secco e atossiche, il ciclo di verniciatura è ad acqua. L'applicazione della finitura effetto cemento avviene tramite spruzzo e spatolatura manuale ottenendo un effetto cemento in tridimensionale. La finitura laccato metallico avviene tramite spruzzo e carteggiatura manuale ottenendo un effetto simile al metallo spazzolato.

Essendo applicate manualmente si possono creare delle zone non uniformi, ma sicuramente di valore e di pregio, in quanto sono lavorazioni artigianali. Per la pulizia usare acqua e detergente (50/50).

The concrete-effect and metal effect lacquer finishes are obtained by using low dry residue and non-toxic paints, through a water-based painting cycle. The concrete-effect finish is applied by manually using a spray and spatula to obtain a three-dimensional concrete effect.

The metal lacquer finish is created by manually spraying and sanding, in order to obtain a brushed metal-effect.

Due to an artisan application, uneven areas might appear, but still valuable and precious as a result of a handcrafted manufacturing. For cleaning purposes, please use water and cleanser in a 50:50 ratio.

## VERNICI | PAINTS

Le vernici utilizzate sono a basso residuo secco e atossiche. Per le essenze e i laccati opachi il ciclo di verniciatura è ad acqua, mentre per i laccati lucidi a solvente. Il tipo di finitura per l'essenza è a poro aperto e la superficie subisce una lavorazione di spazzolatura.

Le vernici all'acqua permettono di ridurre le emissioni di solventi in atmosfera, sono contraddistinte dall'assenza di odori e tutelano la salute dell'operatore e dell'utilizzatore finale.

The paints employed are low-residue ones and atoxic. For the wood and lacquered finishes, water-borne paints are used.

For the lacquered glossy finishes solvent-based paints are used. The wood finish is an open-pore one and the surface is submitted to a brushing process. Water-borne paints allow the reduction of the atmospheric emission of solvents and are characterized by the lack of scent, safeguarding the operator's and end consumer's health.

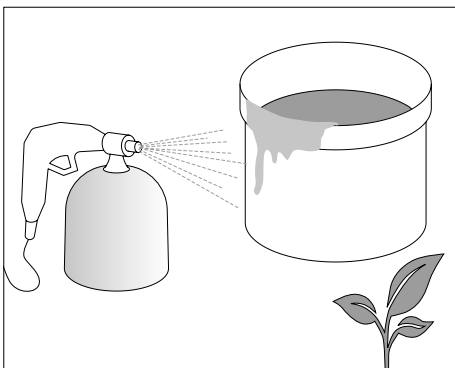

## TOLLERANZE | TOLERANCES

Le parti con finitura in essenza possono subire nel tempo variazioni di colore dovute alla luce, all'umidità e al passare del tempo.

Esistono anche dei margini di tolleranza dovuti a variazione di prodotto per le finiture laccate.

In caso di un completamento successivo dell'ordine, non si garantisce la perfetta eguaglianza di colori con la composizione originaria.

Veneered parts may change colour over time due to exposure to light and humidity as well as the passing of time.

A certain tolerance due to product variation has to be considered also for lacquered finishes.

In case of order completion at a second stage, it's not possible to guarantee a perfect colour-matching with the original composition.

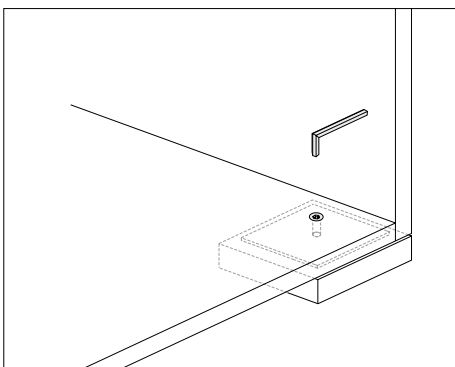

## REGOLAZIONE | ADJUSTMENT

Per le madie e i contenitori la regolazione per la messa a bolla avviene solo tramite piedini livellatori H. 30, posizionati sul fondo e regolabili con chiave a brugola. Questa tipologia di regolazione è possibile solo nei modelli dove è indicato.

I basamenti ed i piedini H. 163 non sono regolabili a parte il piedino centrale H. 163.

For sideboards and storage units the level adjustment occurs only by means of levelling feet H. 30, placed on the bottom and adjustable with hex key. Such type of adjustment is possible only where specified.

The bases and feet H. 163 are not adjustable apart from the central foot H. 163.

**TELAI ANTE VETRO SLIM - BATTENTI E A RIBALTA | FRAMES FOR HINGED AND FLAP SLIM GLASS DOORS**



finitura brown  
brown finish



finitura bianco  
white finish

**TELAI ANTE VETRO UP - BATTENTI | FRAMES FOR HINGED UP GLASS DOORS**



finitura brown - vetro disponibile solo in finitura trasparente grigio  
brown finish - available only in grey transparent glass

**VETRI | GLASSES cat. 1**

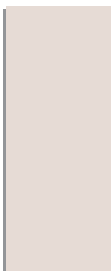

sabbia chiaro  
light sand

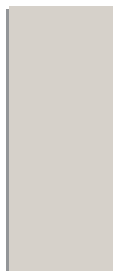

sabbia scuro  
dark sand



corda  
rope



grigio pietra  
stone grey

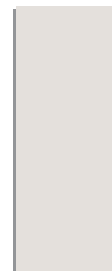

grigio chiaro  
light grey



grigio medio  
medium grey



grigio polvere  
powder grey



giallo cromo  
chrome yellow



verde pompelmo  
grapefruit green



rosso rubino  
ruby red

**VETRI | GLASSES cat. 2**



nero  
black



stopsol fumé  
smoke-grey stopsol



specchio  
mirror



specchio bronzo  
bronze mirror



specchio fumo  
smoke mirror



trasparente  
transparent



trasparente grigio  
grey transparent

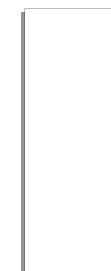

bianco

\* ATTENZIONE: i vetri stopsol fumé e trasparenti lasciano intravedere il telaio sottostante dell'anta vetro Slim.

\* ATTENTION: the smoke-grey stopsol and transparents glasses allow a glimpse of the underlying frame of Slim glass door.

MANIGLIE SLIM | SLIM HANDLES



finitura brown  
brown finish



finitura bianco  
white finish



laccato opaco (disponibile in tutta la gamma colori)  
matt lacquered (available in all the colour range)

MANIGLIE: GOLA e XL - ELEMENTI IN METALLO | HANDLES: GROOVE and XL - METAL ELEMENTS



maniglia Gola  
Groove handle



maniglia XL  
XL handle

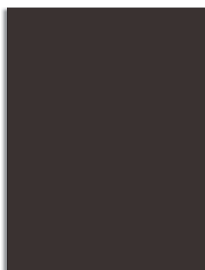

finitura brown  
brown finish

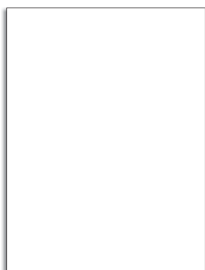

finitura bianco  
white finish



finitura ottone  
brass finish



finitura titanio  
titanium finish

N.B.: La riproduzione dei colori su carta può risultare alterata rispetto agli originali, pertanto queste tinte sono da considerarsi puramente indicative.

N.B.: The reproduction of the colours on paper may be different with respect to the original colours, therefore these shades should be considered representative only.